



**hear**  
TECHNOLOGIES®

The Mix Back is a flexible and affordable 16 x 12 x 2 x 2 monitor mixer. With two stereo and twelve mono outputs, it's a perfect companion to our Hear Back personal monitor system. The mixer is equally at home as a stand alone monitor mixer.

A talk back mic preamp permits talking to any or all master outputs and the intercom output.

The optional 16 button remote connects using a standard CAT5e cable.

#### Input Channel Features:

- 16 quality Mic/Line inputs with passive XLR split
- Pin 1 lift and Mic phantom power switches
- Channel inserts
- Signal/Clip LED indicator
- 100 Hz high-pass filter
- Gain control
- 4-band EQ with separate controls for sweep and cut/boost on mid bands
- Two stereo level and pan controls (ST1 and ST2)
- Twelve mono level controls (1-12)
- Switch selectable effects 1-2 sends



**mix back remote**

**mix back mixer**

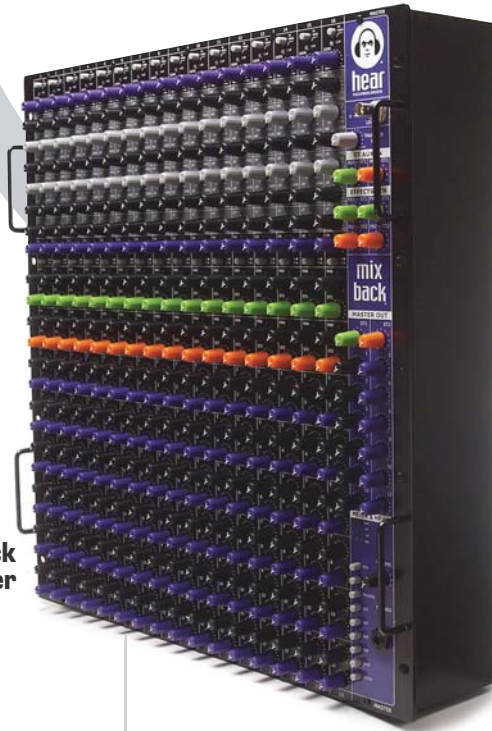

#### Master Features:

- 2 stereo and 12 mono TRS outputs
- Switch selectable meter/headphone monitoring
- 2 stereo TRS balanced effect returns
- Switch assignable FX1/FX2 returns to the 12 mono masters
- Stereo Aux return with level controls to both stereo busses – great for FOH mix or the studio “two mix”
- Buss inputs permit stacking of multiple mixers
- Talk back mic preamp assignable to stereo masters 1 and 2, mono outputs 1-12, and the balanced Intercom/slate output
- Relay contact when the talk back intercom switch is pressed
- 16 button talkback remote connects using standard CAT5e cable
- 16 channels of ADAT and HearBus output

#### Other Features:

- Universal internationally approved internal power supply
- 11 RU chassis
- All analog inputs and outputs are balanced

#### Outputs:

- ST1 L/R
- ST2 L/R
- Mono 1-12
- FX1 Send
- FX2 Send
- Talkback output
- Talkback Relay
- ADAT – 16 Channels
- HearBus – 16 Channels

#### Inputs:

- ST1 L/R
- ST2 L/R
- Mono 1-12
- FX1 L/R
- FX2 L/R
- Stereo Aux inputs
- Talkback Mic
- Talkback Remote control

**mix back**  
™

## mix back | input channel

FRONT PANEL

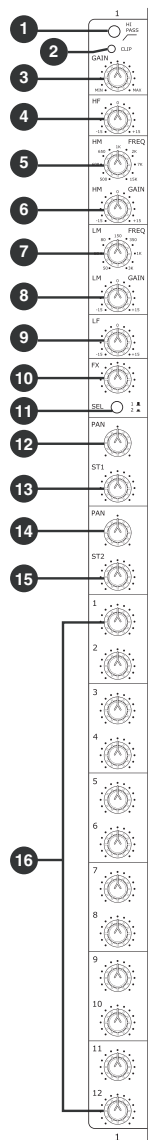

REAR PANEL

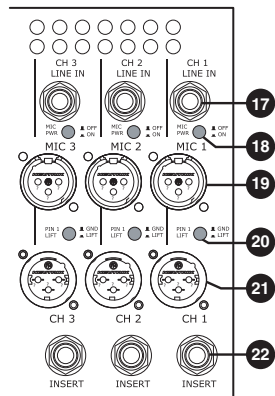

### INPUT CHANNEL

- 1 - Hi-Pass Filter
- 2 - Signal/Clip LED
- 3 - Preamp Gain control
- 4 - HF (Hi Frequency)
- 5 - HM (Hi Mid) Frequency
- 6 - HM Gain control
- 7 - LM (Lo Mid) Frequency
- 8 - LM Gain control
- 9 - LF (Lo Frequency)
- 10 - FX Level
- 11 - FX 1/2 Select
- 12 - ST1 (Stereo 1) Pan
- 13 - ST1 (Stereo 1) Level
- 14 - ST2 (Stereo 2) Pan
- 15 - ST2 (Stereo 2) Level
- 16 - Mono Level 1-12
- 17 - Line Input
- 18 - Phantom Mic Power Switch
- 19 - Mic Input
- 20 - Pin 1 Ground Lift
- 21 - Passive Split XLR Output
- 22 - Channel Insert

## mix back | master section

FRONT PANEL

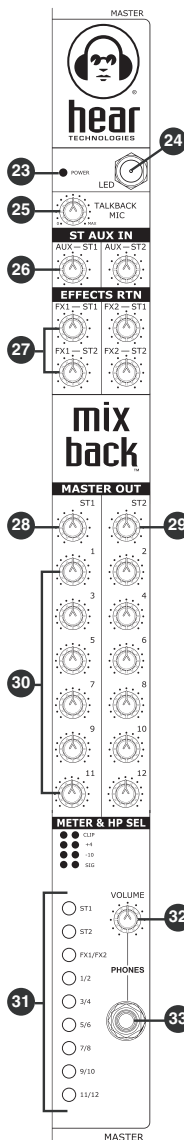

REAR PANEL

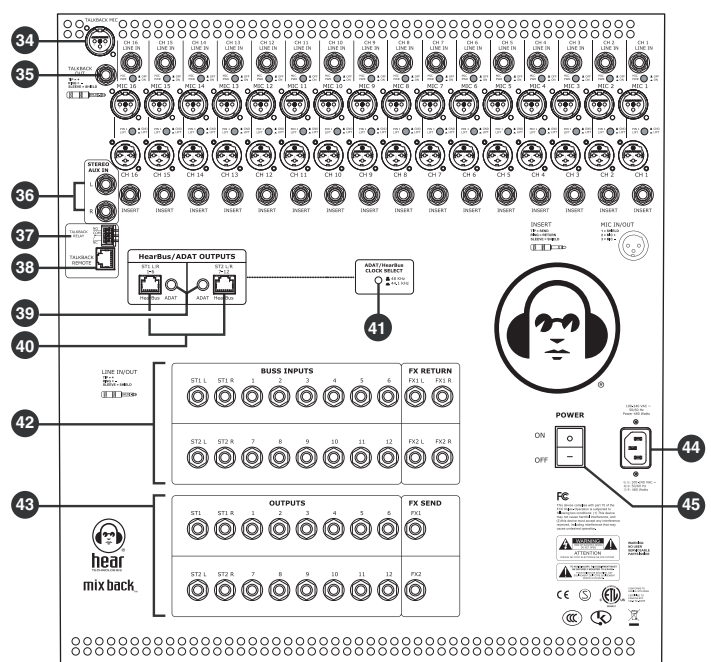

### MASTER SECTION

- 23 - Power LED Indicator
- 24 - UV LED Lamp BNC Connector
- 25 - Talkback Level Control
- 26 - Stereo Auxiliary input level controls
- 27 - Effects 1 to ST1/ST2 and Effects 2 to ST1/ST2 level controls
- 28 - Stereo 1 L/R Master level control
- 29 - Stereo 2 L/R Master level control
- 30 - Mono 1-12 Master level controls
- 31 - Meter/Headphone switches
- 32 - Headphone level control
- 33 - Headphone Output
- 34 - Talkback Mic Input
- 35 - Talkback Output
- 36 - Stereo Aux Inputs
- 37 - Talkback Relay
- 38 - Talkback Remote Control Input
- 39 - ADAT Optical Outputs (2)
- 40 - HearBus Outputs (2)
- 41 - ADAT/HearBus Clock Frequency Selector
- 42 - Buss Inputs (20)
- 43 - Analog Outputs (18)
- 44 - Universal AC Power Supply
- 45 - AC Power Switch

## MIX BACK SPECIFICATIONS

Passive Microphone Split (Each Channel)	
Mic In to Mic Out:	Passive
Mic Power:	+18 VDC
Pin 1 Lift:	Output XLR
Mic Input to Insert Output	
<i>Conditions: +14 dBu input, Gain full CCW, 150 Ω, Balanced</i>	
Frequency Response:	20 Hz to 20 KHz, +/- 0.05 dBu 10 Hz to 120 KHz, +/- 0.3 dBu
THD+N:	0.002%, 22 Hz to 22 KHz, unweighted
IMD:	0.003%
EIN:	-121 dBu, 150 Ω Source, -40 dBu input
Mic Pre to Master Output	
<i>Conditions: 0 dBu input, Gain full CCW, 150 Ω, Balanced</i>	
Frequency Response:	20 Hz to 20 KHz, +/- 0.5 dBu
THD+N:	0.004%, 22 Hz to 22 KHz, unweighted
IMD:	0.004%
Maximum Gain:	60 dBu, EQ Flat
Line Inputs to Insert Outputs	
<i>Conditions: +18 dBu input, Gain full CCW, 150 Ω, Balanced</i>	
Frequency Response:	20 Hz to 20 KHz, +/- 0.3 dBu
THD+N:	0.005%, 22 Hz to 22 KHz, unweighted
IMD:	0.005%
Input Impedance:	10K Ω, balanced
Attenuation:	18 dB
Channel Equalization	
Hi Frequency:	10 KHz shelving, +/- 15 dB
Hi Mid Frequency:	500 Hz to 15 KHz, +/- 15 dB
Lo Mid Frequency:	50 Hz to 3 KHz, +/- 15 dB
Lo Frequency:	100 Hz shelving, +/- 15 dB
Hi-Pass Filter:	100 Hz, 3 pole, 18 dB/Octave

Note: 1) 0 dBu = 0.775 V rms  
2) Talkback relay = 1 amp maximum

Buss Inputs to Master Outputs	
<i>Conditions: +4 dBu input, 150 Ohms, Balanced</i>	
Frequency Response:	20 Hz to 20 KHz, +/- 0.2 dBu
THD+N:	0.005%
IMD:	0.005%
Input Impedance:	10K Ω, balanced
Digital Output	
ADAT Output:	24 Bit, 44.1 KHz / 48 KHz Selectable
HearBus Output:	24 Bit, 44.1 KHz / 48 KHz Selectable
ADAT/HearBus 1:	Master 1 L/R, Channels 1-6
ADAT/HearBus 2:	Master 2 L/R, Channels 7-12
Analog Line Outputs	
Maximum Output Level:	+24 dBu, TRS Balanced
Output Impedance:	121 Ω, balanced
Talkback Mic Pre Amplifier	
<i>Conditions: -40 dBu input, 150 Ω, Balanced</i>	
Frequency Response:	20 Hz to 20 KHz, +/- 1.5 dBu
Gain:	Off to 50 dBu, variable
Line Output:	121 Ω, TRS Balanced
Input Impedance:	1K Ω, balanced
THD:	0.05%
IMD:	0.09%
Remote Control:	1-12, ST1, ST2, COM, ALL
Remote Cable:	CAT5e, 500 ft. max, wired pin-to-pin
Effects (FX) Return	
<i>Conditions: +4 dBu input, 150 Ω, Balanced</i>	
Frequency Response:	20 Hz to 20 KHz, +/- 0.5 dBu
Gain, FX return to Master:	1 dB, Master at center
THD+N:	0.0025%, 20 Hz to 20 KHz
IMD:	0.0027%, 20 Hz to 20 KHz
Input Impedance:	10K Ω, balanced
Maximum Input Level:	+10 dBu, control centered

Stereo Aux Input	
<i>Conditions: +4 dBu input, 150 Ω, Balanced</i>	
Frequency Response:	20 Hz to 20 KHz, +/- 0.5 dBu
Gain:	Off to +6 dBu, Aux to Stereo Masters
THD+N:	0.0033%, 20 Hz to 20 KHz
IMD:	0.004%, 20 Hz to 20 KHz
Input Impedance:	10K Ω, balanced
Maximum Input Level:	+8 dBu
Power Supply (Universal)	
Input Voltage:	100 to 240 VAC~, 50-60 Hz
Input Current:	2 Amps
Maximum Continuous Input Power:	240 Watts
Fuse (Internal):	3.15 Amp
Inrush:	60 Amps, 2 mSec
Short Circuit Protection:	Yes
AC Input Connector:	IEC 320-C14, International
Agency Listing:	FCC class B, CISPR 22 class B, IEC 60950-1 safety, EN 61000-4-2, 4-4, 4-5
Physical	
Construction:	Steel Chassis / Steel Front Panel
Size (with 1" handles):	19.23" H x 19" W x 5.35" D (488mm H x 482.6mm W x 135mm D)
Unit Weight:	30.8 lbs (14 kg)
Mounting:	Standard rack mount, 11RU
Shipping Size:	10.55" H x 25.0" W x 24.53" D (268mm H x 635mm W x 623mm D)
Shipping Weight:	42.9 lb. (19.5 kg)

\*Specifications and features subject to change without notice.

Part No. LIT002720CS  
© 2007, July 2007